

FEDERAL SUPPLY CLASS  
5325

REV.  
D

MA3279™

RATIONALE

THREAD PITCH DIAMETER CORRECTED, CALLOUT FOR DASH 152, DASH 252, DASH 303, AND DASH 279 CORRECTED.

SAE Technical Standards Board Rules provide that: "This report is published by SAE to advance the state of technical and engineering sciences. The use of this report is entirely voluntary, and its applicability and suitability for any particular use, including any patent infringement arising therefrom, is the sole responsibility of the user." SAE reviews each technical report at least every five years at which time it may be revised, reaffirmed, stabilized, or cancelled. SAE invites your written comments and suggestions.

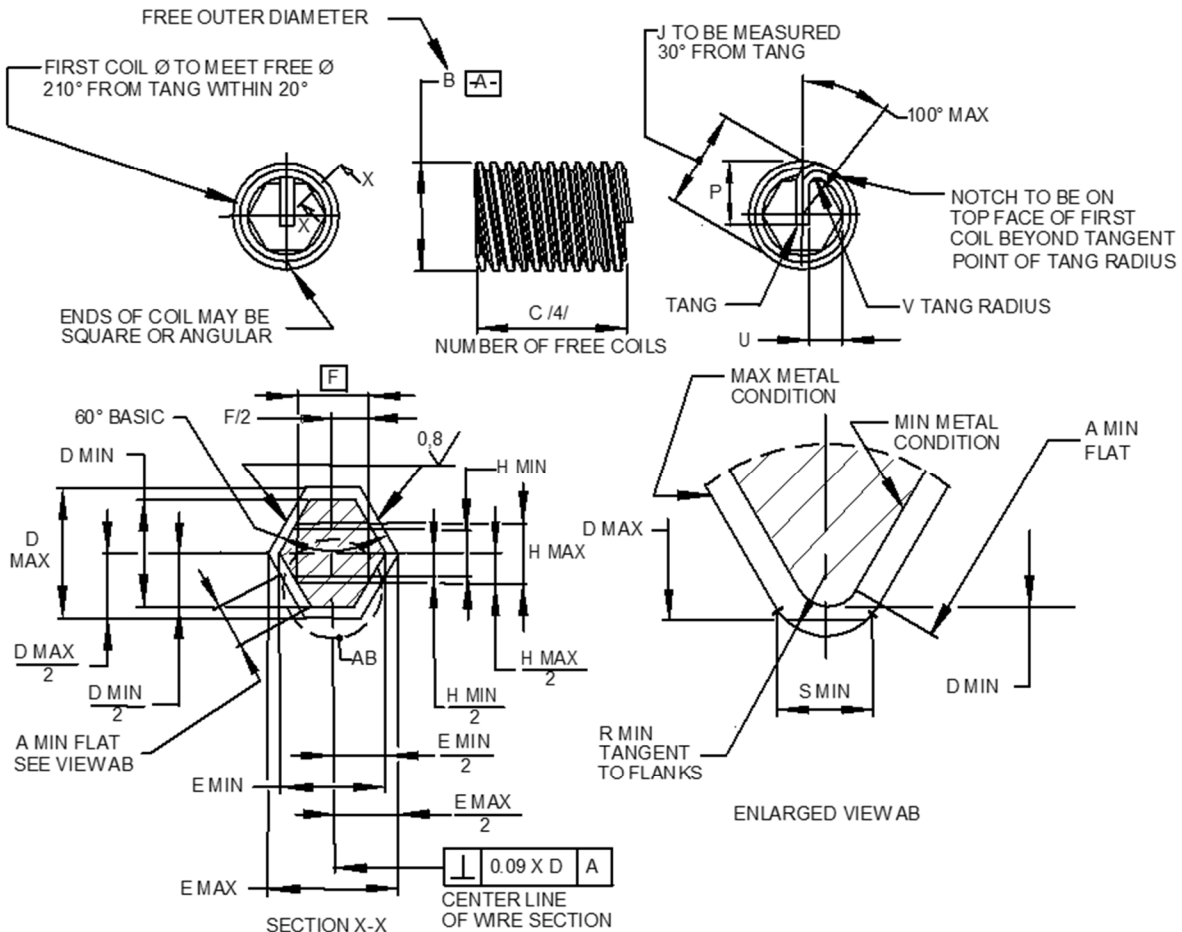
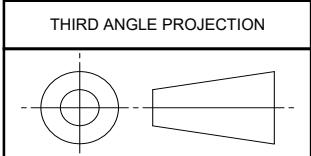

FIGURE 1

SAE values your input. To provide feedback on this Technical Report, please visit <http://standards.sae.org/MA3279D>



CUSTODIAN: E-25

PROCUREMENT SPECIFICATION: MA1565



METRIC AEROSPACE STANDARD

INSERT, SCREW THREAD, HELICAL COIL, METRIC SERIES, FREE RUNNING, CRES, UNCOATED

MA3279™  
SHEET 1 OF 6

REV.  
D

ISSUED 1981-09 REAFFIRMED 2012-12 REVISED 2019-02

TABLE 1

THREAD Ø	THREAD PITCH	PART NUMBER 1 X Ø NOMINAL LENGTH /1/	PART NUMBER 1.5 X Ø NOMINAL LENGTH /1/	PART NUMBER 2 X Ø NOMINAL LENGTH /1/	PART NUMBER 2.5 X Ø NOMINAL LENGTH /1/	PART NUMBER 3 X Ø NOMINAL LENGTH /1/	A MIN
2	0.4	MA3279-140	MA3279-190	MA3279-240	MA3279-290	MA3279-340	0.074
2.2	0.45	MA3279-100	MA3279-150	MA3279-200	MA3279-250	MA3279-300	0.082
2.5	0.45	MA3279-101	MA3279-151	MA3279-201	MA3279-251	MA3279-301	0.082
3	0.5	MA3279-102	MA3279-152	MA3279-202	MA3279-252	MA3279-302	0.105
3.5	0.6	MA3279-103	MA3279-153	MA3279-203	MA3279-253	MA3279-303	0.160
4	0.7	MA3279-104	MA3279-154	MA3279-204	MA3279-254	MA3279-304	0.163
5	0.8	MA3279-105	MA3279-155	MA3279-205	MA3279-255	MA3279-305	0.209
6	1	MA3279-106	MA3279-156	MA3279-206	MA3279-256	MA3279-306	0.267
7	1	MA3279-107	MA3279-157	MA3279-207	MA3279-257	MA3279-307	0.267
8	1	MA3279-108	MA3279-158	MA3279-208	MA3279-258	MA3279-308	0.267
8	1.25	MA3279-109	MA3279-159	MA3279-209	MA3279-259	MA3279-309	0.415
10	1	MA3279-141	MA3279-191	MA3279-241	MA3279-291	MA3279-341	0.267
10	1.25	MA3279-110	MA3279-160	MA3279-210	MA3279-260	MA3279-310	0.415
10	1.5	MA3279-111	MA3279-161	MA3279-211	MA3279-261	MA3279-311	0.511
12	1.25	MA3279-112	MA3279-162	MA3279-212	MA3279-262	MA3279-312	0.415
12	1.5	MA3279-113	MA3279-163	MA3279-213	MA3279-263	MA3279-313	0.511
12	1.75	MA3279-114	MA3279-164	MA3279-214	MA3279-264	MA3279-314	0.654
14	1.5	MA3279-115	MA3279-165	MA3279-215	MA3279-265	MA3279-315	0.511
14	2	MA3279-116	MA3279-166	MA3279-216	MA3279-266	MA3279-316	0.799
16	1.5	MA3279-117	MA3279-167	MA3279-217	MA3279-267	MA3279-317	0.511
16	2	MA3279-118	MA3279-168	MA3279-218	MA3279-268	MA3279-318	0.799
18	1.5	MA3279-119	MA3279-169	MA3279-219	MA3279-269	MA3279-319	0.511
18	2	MA3279-120	MA3279-170	MA3279-220	MA3279-270	MA3279-320	0.799
18	2.5	MA3279-121	MA3279-171	MA3279-221	MA3279-271	MA3279-321	1.017
20	1.5	MA3279-122	MA3279-172	MA3279-222	MA3279-272	MA3279-322	0.511
20	2	MA3279-123	MA3279-173	MA3279-223	MA3279-273	MA3279-323	0.799
20	2.5	MA3279-124	MA3279-174	MA3279-224	MA3279-274	MA3279-324	1.017
22	1.5	MA3279-125	MA3279-175	MA3279-225	MA3279-275	MA3279-325	0.511
22	2	MA3279-126	MA3279-176	MA3279-226	MA3279-276	MA3279-326	0.799
22	2.5	MA3279-127	MA3279-177	MA3279-227	MA3279-277	MA3279-327	1.017
24	2	MA3279-128	MA3279-178	MA3279-228	MA3279-278	MA3279-328	0.799
24	3	MA3279-129	MA3279-179	MA3279-229	MA3279-279	MA3279-329	1.234
27	2	MA3279-130	MA3279-180	MA3279-230	MA3279-280	MA3279-330	0.799
27	3	MA3279-131	MA3279-181	MA3279-231	MA3279-281	MA3279-331	1.234
30	2	MA3279-132	MA3279-182	MA3279-232	MA3279-282	MA3279-332	0.799
30	3	MA3279-133	MA3279-183	MA3279-233	MA3279-283	MA3279-333	1.234
33	2	MA3279-134	MA3279-184	MA3279-234	MA3279-284	MA3279-334	0.799
33	3	MA3279-135	MA3279-185	MA3279-235	MA3279-285	MA3279-335	1.234
36	2	MA3279-136	MA3279-186	MA3279-236	MA3279-286	MA3279-336	0.799
36	3	MA3279-137	MA3279-187	MA3279-237	MA3279-287	MA3279-337	1.234
39	2	MA3279-138	MA3279-188	MA3279-238	MA3279-288	MA3279-338	0.799
39	3	MA3279-139	MA3279-189	MA3279-239	MA3279-289	MA3279-339	1.234



### METRIC AEROSPACE STANDARD

INSERT, SCREW THREAD, HELICAL COIL,  
METRIC SERIES, FREE RUNNING, CRES, UNCOATED

MA3279™  
SHEET 2 OF 6

REV.  
D